

Lan Handling Technologies Shuttle

For safe, reliable product sterilisation



Lan Handling Technologies



Shuttle with jars

Shuttle

Benefits

Offering important advantages in the food sterilising process, Lan Handling Technologies' shuttle delivers unparalleled safety, reliability and durability.

An integrated control interface guarantees 100% effective product sterilisation and the system's unique tongue solution works without any mechanical parts in the steriliser.

How it works

Loading

- A chain conveyor transports carriers with product onto the shuttle
- The shuttle is driven to the steriliser
- The slide docks at the steriliser
- The tongue lifts up the carriers and moves them inside the steriliser.

Unloading

- A reversed cycle of the above

Related products

- ▶ Stack conveyors
- ▶ (Un)loading systems

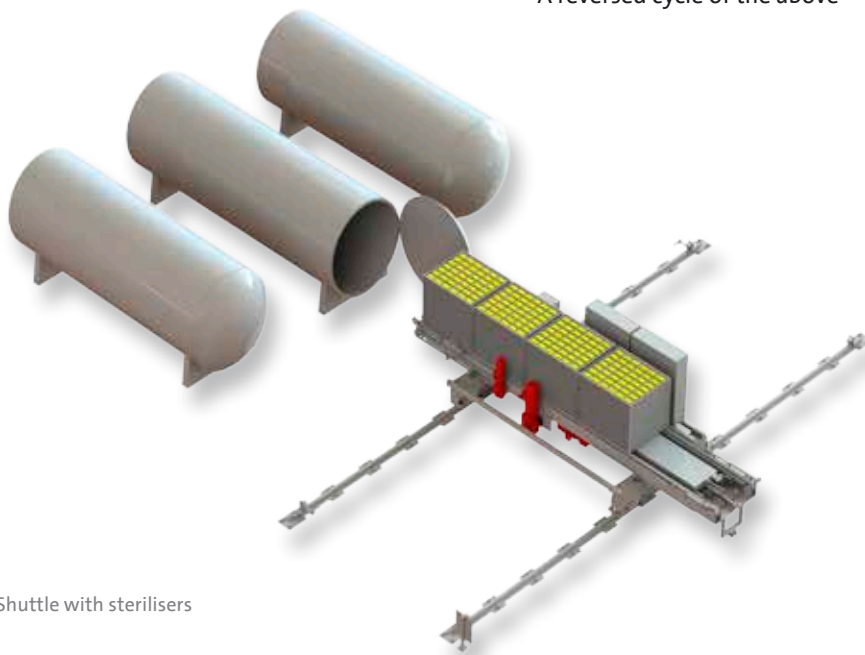

Shuttle with sterilisers

Technical Specifications

Construction

- > A base frame with four wheels to travel along the steriliser, pick-up and drop-off points
- > A slide to dock the steriliser and bridge the gap at the door. This includes a system for an accurate alignment and a chain conveyor to transfer the carriers on and off the shuttle
- > A tongue to load and unload the steriliser
- > Onboard electrical and safety control interface

Solution types

- > Single or double slides
- > For sterilisers of all sizes
- > Adapted solutions for continuous and Shaka sterilisers

Material

Easy to clean stainless steel AISI 304 construction

Compatibility

- > All suppliers of sterilisers



Lan Handling Technologies

Jules Verneweg 123
5015 BK Tilburg
The Netherlands

Phone +31 13 532 25 25
info@lanhandling.com
www.lanhandling.com